

Standard equipment/Optional equipment

Standard equipment

- Standardized front module and load carrier modules with electrically powered lifting-spindles
- Different types of customized, interchangeable load carrier modules
- Capacity of 800 kg / 1000 kg / 1600 kg / 2000 kg
- Load-carrier modules are equipped with PU-tires with diameter 250 mm
- Possibility to lift different sizes of loads on trolleys from 400 x 600 up to 1200 x 2000 mm
- Control console on truck and additional lift-operation at the load carrier module
- CAN bus communication between tractor and modules
- Automatic tractor drive-lock when load-carrier modules are lowered
- Continuously monitored electrical steering system with active steering against drifting in curves
- Adjustable lifting height: 0 - 80 mm
- Lifting speed max. 10 mm/s
- Economical energy consumption
- Power connector to tractor and between modules
- Crab motion for obliquely side positioning of the train
- Operating hour meter and maintenance indicator
- Driving backwards possible for short distance
- Slow speed in curves until the last axle of the train is back in straight direction
- Lowering only possible with activated handbrake
- Different load carrier modules available: C-frame, E-frame with fixed or adjustable forks, Bridge-frame, Platform-frame, QS-frame
- Linde red/anthracite paintwork

Requires adaptation of the tractor (electrical connector, control console)

Optional equipment

- Weather protection with roll-up curtain at the load carrier modules
- Customized load carrier modules adapt to existing trolleys
- Glide- and wear strips at trolley contact-surfaces
- Other load/trolley dimensions
- Weather protection with printed logo
- Outdoor package with SE-twin-tires
- Lighting equipment at the last load carrier module (Rear-, brake- and flashing light, rotating light)
- Remote diagnostics
- Alternative paintwork
- Further options on request

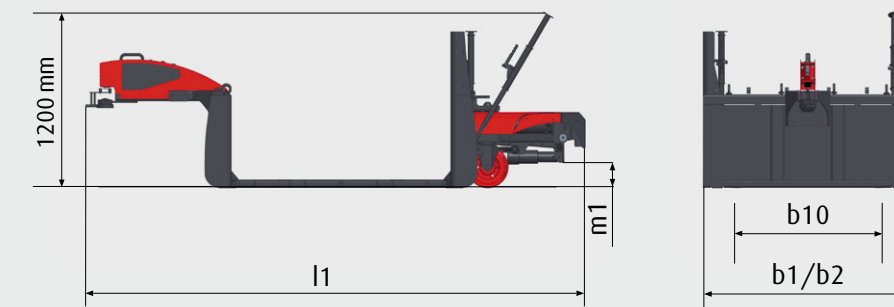
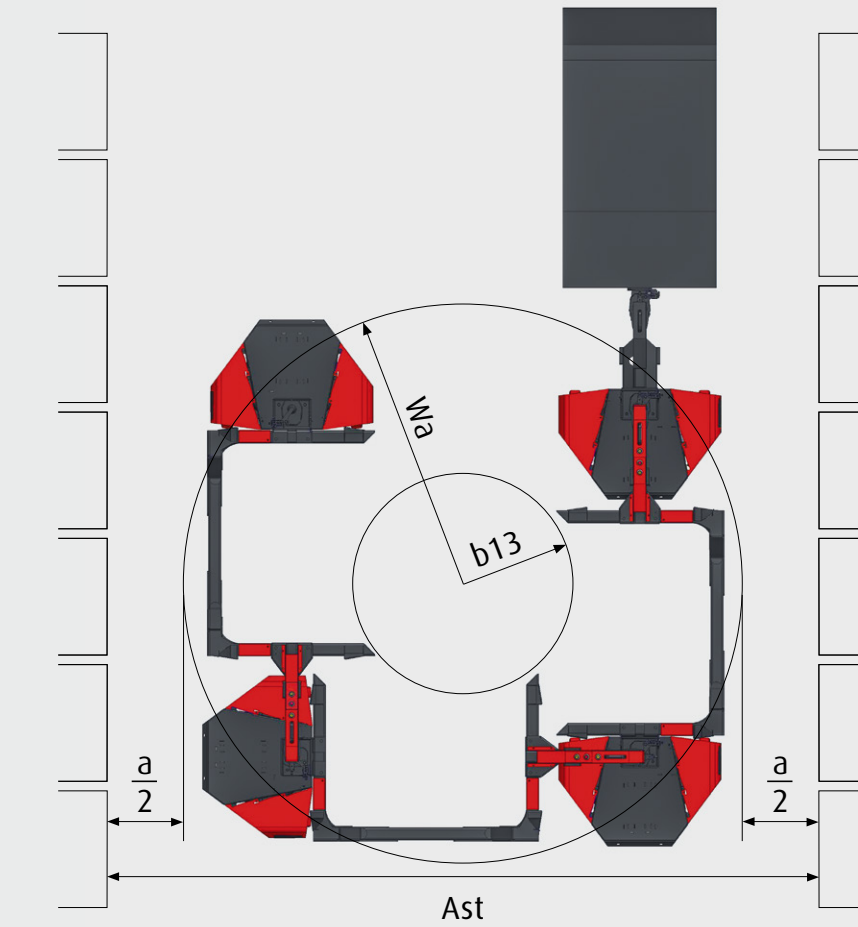

Safety

The innovative Factory Train Compact (FTC) brings a new dimension to efficient and safe material flows for production plants. The 3-point construction ensures that all wheels of the train remain in constant contact to the ground also on uneven surface applications. Raising goods on trolleys with the load carriers above the floor creates a load protecting, low-noise, low-wear and safe load handling process. An integral drive-lock prevents the tractor moving with lowered load carriers.

Performance

The modular train principle with its interchangeable carriers is an efficient and cost-effective solution for a rapid external and internal load transfer. It allows for simultaneous transport of various goods on trolleys. The fully electrical steering is monitored permanently and gives a best in class directional driving stability. The shock absorbing elements combined with the optional available weather protection secure the goods from environmental impact. In case of route/requirement changes, load carriers can be swapped conveniently or combined differently to enhance the handling capacity and to keep the performance level high.

Comfort

The train delivers a comfortable and smooth driving and the quiet operating electrical spindle-lifting can be pre-lowered from the tractor or operated directly from the load carrier module. Load carriers for two or three trolleys keep the train and the walking distances short and allow for a comfortable follow up on internal



deliveries. This, combined with the upright standing position for opening and closing the comfort-class weather protection, offers the best possible ergonomics for the operator.

Reliability

The FTC load carrier modules are designed for consistent reliability in demanding outdoor and indoor applications. The rugged construction of the low-maintenance modules, the backlash-free connections and the sturdy construction of the load carrier modules guarantee safe and stable transports for years.

Serviceability

Economy and durability of the FT Compact load carrier modules result in easy diagnosis and preventive maintenance. The CAN bus system enables all unit data to be read out for inspection when service is due or for the change of parameters. Easy accessibility of all components employed plays an additional part in keeping train uptime high.

Product information

Directionally stable train

- Fully electrical steering, permanently monitored for best manoeuvrability
- Optimized driving-behaviour: fully electrical steering with active curve correction
- Train designed for a superbly controlled narrow cornering



Serviceability

- Easily maintained basic construction
- CAN bus controller with data memory
- Wheels and rollers are easily accessible for exchange
- Functional elements and bearings are service-friendly accessible and exchangeable



Operation

- Time-saving pre-lifting and pre-lowering of the load carriers operated from the control console at the tow tractor
- For on-site-control the lift can be operated directly at the module
- Console provides visual feedback of lift-units positions
- CAN bus control system avoids driving with lowered load carriers

Energy management

- Energy-optimized lifting system
- Reduced rolling resistance by optimized bearings



Lifting device

- Load carrier module lifting height 0 - 80 mm
- Form-fitted trolley locking
- Quiet, electrically powered recirculating ball screw spindles for lifting have integrated shock absorption

Silent

- Silent lifting and lowering due to spindle drive
- Backlash-free load-carrier-module connections
- Suspension and tight fits avoid noise generation

Safety

- Drive lock function: The train cannot be driven before the load is lifted
- Lowering only possible with activated handbrake
- Slow speed in curves until the last axle of the train is back in straight direction



Module / load carrier coupling

- Unique train without drawbars but articulated steering system
- No fit tolerances between module - load-carrier connections
- Silent operating train

Linde Material Handling GmbH, Postfach 10 0136, 63701 Aschaffenburg, Germany
Phone +49.60 21.99-0, Fax +49.60 21.99-15 70, www.linde-mh.de, info@linde-mh.de



Key characteristics (according VDI 2198)

	Neumaier									
	1.1	1.2	1.2a	1.5	1.6	1.8	1.9			
Characteristics	1.1	Manufacturer		Neumaier	Neumaier	Neumaier	Neumaier	Neumaier	Neumaier	
	1.2	Model designation		Front module FT08 C / FT10 C	Front module FT16 C / FT20 C	C-frame / E-frame	C-frame / E-frame	QS- frame / Platform-frame	Bridge Frame	
Weights	1.2a	Series		8961	8961	8961	8961	8961	8961	
	1.5	Load capacity ¹⁾	Q[t]	0.8/1.0	1.6/2.0	0.8/1.0	1.6/2.0	0.8/1.0/1.6/2.0	0.8/1.0/1.6/2.0	
	1.6	Load centre		-	-	-	-	-	-	
	1.8	Axle centre to fork		-	-	-	-	-	-	
	1.9	Wheelbase		-	-	-	-	-	-	
	2.1	Service Weight ²⁾	[kg]	210/280	280/350	310	410	600	600	
	Wheels/Tyres	3.1	Tyres ³⁾		bandage tyres	bandage tyres	bandage tyres	bandage tyres	bandage tyres	bandage tyres
		3.2	Tyres size, front		-	-	-	-	-	-
		3.3	Tyres size, rear ⁴⁾		250	250	250	250	250	250
3.5		Wheels, number ⁵⁾		2	2/4	2	2/4	2/4	2/4	
3.6		Track width, front	b10[mm]	880/1250	1250/1600	880/1250	1250/1600	880/1250/1600 ⁶⁾	880/1250/1600 ⁶⁾	
Dimensions		4.1	Mast/fork carriage tilt, forward/backward		-	-	-	-	-	-
	4.2	Height of mast, lowerered		-	-	-	-	-	-	
	4.4	Lift	h3[mm]	0-80	0-80	0-80	0-80	0-80	0-80	
	4.4d	Lift function		electrical spindles	electrical spindles	electrical spindles	electrical spindles	electrical spindles	electrical spindles	
	4.5	Height of mast, extended		-	-	-	-	-	-	
	4.12	Towing coupling height	h10[mm]	front side: tractor	front side: tractor	-	-	-	-	
	4.15	fork height, lowered		-	-	-	-	-	-	
	4.19	Overall length ⁷⁾	l1[mm]	1380	1380	2960/3060/3760/4660	2960/3060/3760/4660	3060/3160/3860/4760	3060/3160/3860/4760	
	4.21	Overall width	b1[mm]	1060	1475	1100/1300	1475	1475	1475	
	4.21.6	Load Length	l6[mm]	-	-	1240/1240/1840/2740	1240/1240/1840/2740	1240/1240/1840/2740	1240/1240/1840/2740	
	4.21.7	Load width	b12[mm]	-	-	840/1040/1240/1240	840/1040/1240/1240	840/1040/1240/1240	840/1040/1240/1240	
	4.22	Fork dimension		-	-	-	-	-	-	
	4.25	Fork spread, min/max		-	-	-	-	-	-	
	4.31	Ground clearance ⁸⁾	m1[mm]	130	130	130	130	130	130	
	4.35	Turning radius of the train ⁹⁾	Wa[mm]	2100	2300	2100	2300	2100/2100/2300/2300	2100/2100/2300/2300	
4.36	Minimum pivoting point distance		-	-	-	-	-	-		
Performance	5.2	Lifting speed, with/without load	[m/s]	0,01	0,01	0,01	0,01	0,01	0,01	
	5.3	Lowering speed, with/without load	[m/s]	0,01	0,01	0,01	0,01	0,01	0,01	
	5.7	Climbing ability, with/without load	[%]	see tractor diagramm	see tractor diagramm	see tractor diagramm	see tractor diagramm	see tractor diagramm	see tractor diagramm	
	5.10	Service brake		-	-	-	-	-	-	
	6.2	Lift motor rating at SE 15%	[kW]	0,216	0,216	0,216	0,216	0,216	0,216	
8.5	Towing coupling: design/type		front Linde, train. System Neumaier	front Linde, train. System Neumaier	System Neumaier	System Neumaier	System Neumaier	System Neumaier		

¹⁾ Values analog to FT08 C / FT10 C / FT16 C / FT20 C

²⁾ Values analog to track widths front (see 3.6)

³⁾ Optional outdoor package available with SE twin tyres

⁴⁾ Tyres size FT16 C / FT20 C with SE twin tyres: 306 mm

⁵⁾ The wheels of FT20 C are fitted with twin tyres

⁶⁾ Track width 880/1250 mm for load capacity 0.8/1.0t; track width 1250/1600 mm for load capacity 1.6/2.0t

⁷⁾ Values analog to load dimensions 1200x800 / 1200x1000 / 1800x1200 / 2700x1200 mm

⁸⁾ Ground clearance FT16 C / FT20 C with SE twin tyres: 186 mm

⁹⁾ Value given only for load dimension 1200x800 mm

Additional details

		Neumaier		Neumaier		Neumaier		Neumaier	
		FT08 C / FT10 C	FT16 C / FT20 C	FT16 C / FT20 C	FT16 C / FT20 C	FT16 C / FT20 C	FT16 C / FT20 C	FT16 C / FT20 C	FT16 C / FT20 C
Manufacturer		Neumaier		Neumaier		Neumaier		Neumaier	
Model designation		FT08 C / FT10 C		FT16 C / FT20 C		FT16 C / FT20 C		FT16 C / FT20 C	
Series		8961		8961		8961		8961	
Application		Indoor/Outdoor		Indoor/Outdoor		Indoor/Outdoor		Indoor/Outdoor	
Tractor adaptation		Power socket 48V / 80V operation panel		Power socket 48V / 80V operation panel		Power socket 48V / 80V operation panel		Power socket 48V / 80V operation panel	
Lift function		Scissor lifting		Scissor lifting		Scissor lifting		Scissor lifting	
Steering system		Fully electrical steering		Fully electrical steering		Fully electrical steering		Fully electrical steering	
Suspension		serially / integrated into modules (stroke: 15 mm)		serially / integrated into modules (stroke: 15 mm)		serially / integrated into modules (stroke: 15 mm)		serially / integrated into modules (stroke: 15 mm)	
Opening for loading/unloading									
C-frame/E-frame		one side (changeable)		one side (changeable)		one side (changeable)		one side (changeable)	
Bridge-frame		open to both sides		open to both sides		open to both sides		open to both sides	
QS-frame		open to both sides		open to both sides		open to both sides		open to both sides	
Length of train (without tractor)¹⁰⁾		(m)							
with 2 load carrier modules		5,87		5,87		5,63		5,63	
with 3 load carrier modules		8,14		8,14		8,14		8,14	
with 4 load carrier modules		10,41		10,41		10,41		10,41	
with 5 load carrier modules		12,68		12,68		12,68		12,68	
Weight of train (without tractor)¹⁰⁾		(kg)							
with 2 load carrier modules		830		900		1100		1170	
with 3 load carrier modules		1140		1210		1510		1580	
with 4 load carrier modules		1450		1520		1920		1990	
with 5 load carrier modules		1760		1830		2330		2400	
Load-time diagram for SE-wheels									
Options									
Weather protection		√		√		√		√	
weighing system		√		√		√		√	
Graphical display, digital		√		√		√		√	
Lighting in accordance with regulations		√		√		√		√	

¹⁰⁾ Values for load dimension 1200x800 mm

Front module

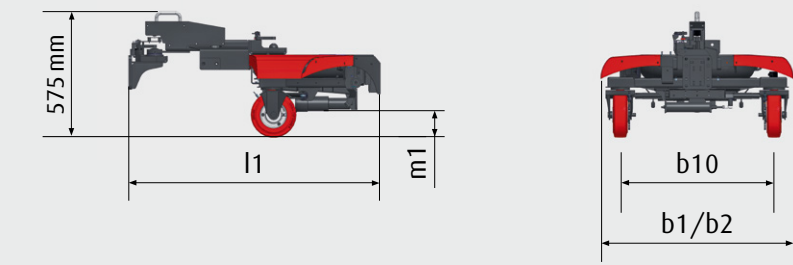

C-frame / E-frame

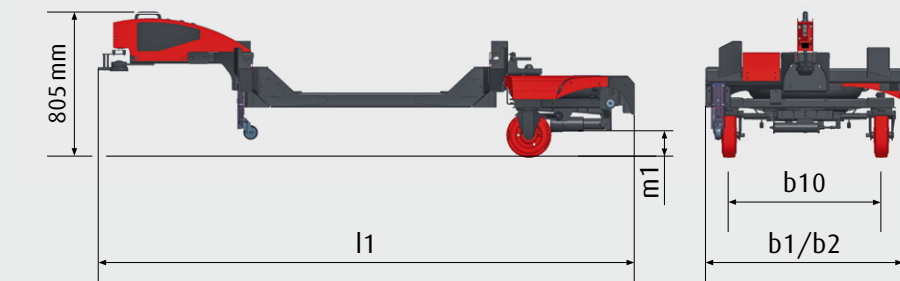

Bridge Frame

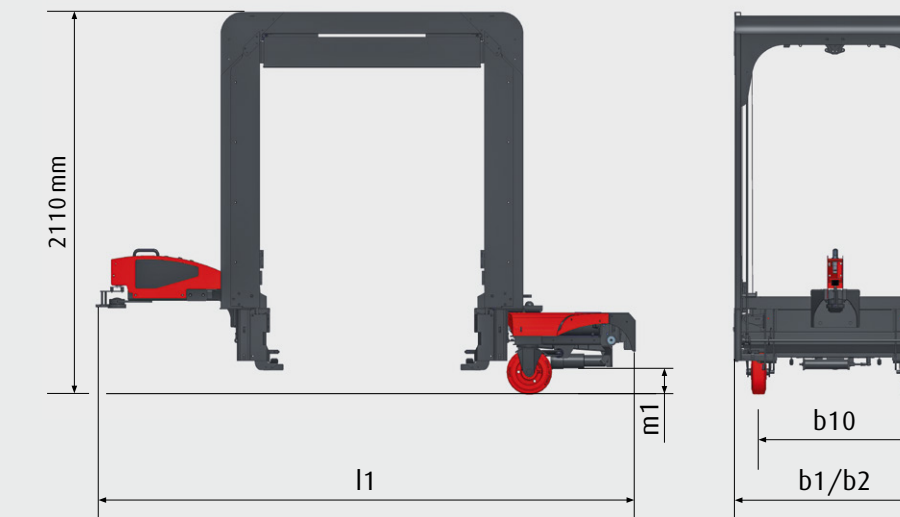

QS-frame

